

T-ERA

New Era in power distribution technology

It's what the future is all about

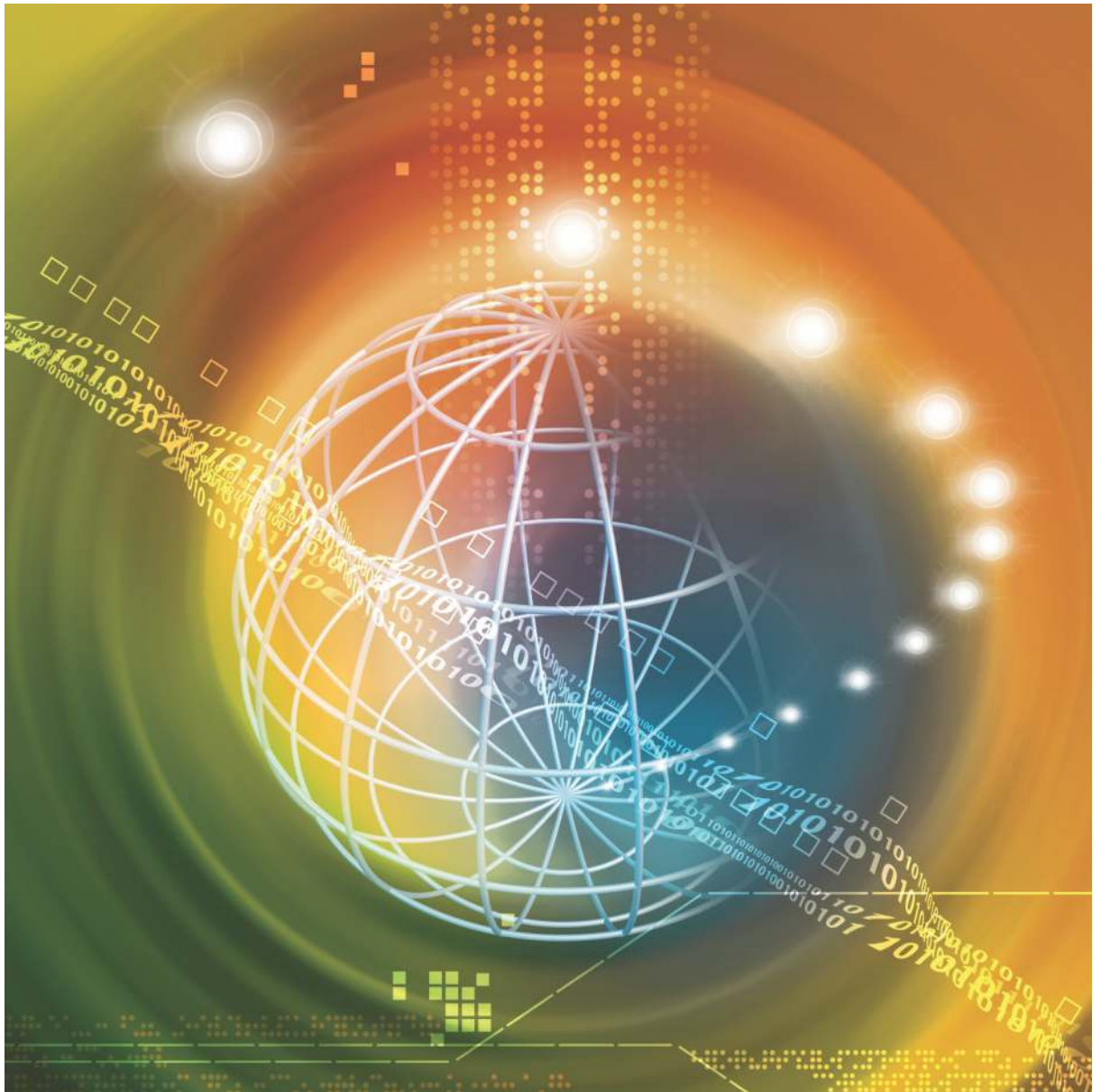

L&T Electrical & Automation (E&A) designs, manufactures and market a wide range of low voltage and medium voltage electrical systems, control and automation systems, electrical products and metering and protection systems.

T-Era is a range of low voltage switchgear designed to match international standards of quality. It makes your applications safe, uses space economically and diminishes hazards. T-Era saves you time and energy, enhancing cost optimisation. Used in a range of applications, this is the eco-friendly choice.



We believe tomorrow is not just an extension of today. It's a whole new era. An era where innovation powers change across multiple dimensions – space, time, cost. In fact, an era where innovation revolutionizes thought.

The T-Era is tomorrow's electrical distribution system. Today.



T-Era is designed to maximize safety in operation and during maintenance. It complies with international health and safety standards to ensure safety of operators at all times.

unless the compartment door is closed. This makes our switchboards completely safe for operators.

Interlocks

In the PCC (Power Control Centre) as well as MCC (Motor Control Centre), all operations are behind closed doors - doors need not be opened either to change the condition of the module/ACB or for the basic testing of the control circuit of the module/ACB.

Unless the ACB/module is in isolated condition, its compartment door cannot be opened. Conversely, the ACB/module cannot be put in or out of service position,

To prevent inadvertent operation, the interlocks provided by us exceed the requirements prescribed by international standards.

Arc-resistant design

The vertical busbars of MCC are completely enclosed in fire retardant, non-hygroscopic polyester glass supports with high tracking index. This arrangement ensures that the chances of arc initiation are remote, thus leading to an arc-resistant design.

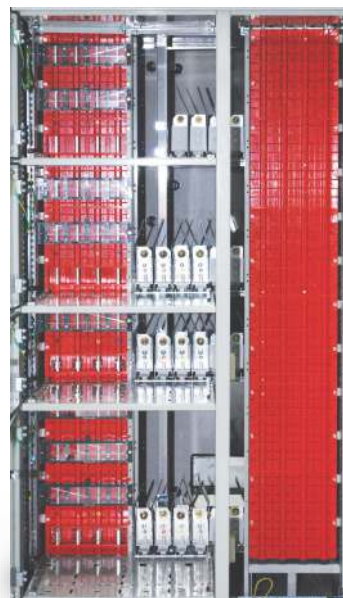

Arc faults are a type of short circuit with a huge energy level of up to 20 MW per cycle, very high temperature up to 3000° C, and pressure rise up to 3 atm. resulting in extensive damage, monetary loss and even personnel injury.

When an internal arc fault occurs, the mechanical parts are subjected to considerable amount of stress due to development of high pressure in the enclosure. To avoid the destruction of the switchgear assembly it is necessary to integrate over-pressure relief systems by way of ventilation openings. Besides this, the people close to the switchgear are also at risk during the internal arc fault. The safety of operators against hot gases, radiation and fragmentation of the enclosure must be ensured.

To comply to the internal arc withstand test, an enclosure system has been created which minimizes the possibility of an arc fault and also limits the effect of accidental arcs.

To achieve this, we have incorporated the following design concepts:

- Insulated busbar system
- Spring loaded locking device
- Fully enclosed distribution system
- Overpressure release system
- Phase barriers

The equipment is tested to ensure that:

- Correctly secured doors, covers etc. do not open
- Parts of assembly which may cause a hazard do not fly off
- Arcing does not cause holes to develop in the freely accessible external parts of the enclosure as a result of burning or other effects
- Indicators do not ignite
- The protective circuit is still effective
- The assembly is capable of confining the arc to the defined area where it is ignited and there is no propagation of the arc to other areas within the assembly
- The switchgear assembly withstands dielectric voltage at a value of 1.5 times the rated operational voltage for 1 minute

We offer you internal arc withstand switchboards complying with IEC 61641.

Form 4 Switchboards

Forms of separation complying with IEC 61439 refer to the internal separation provided in the switchboard. While working on any part of the switchboard, there is a possibility of accidental access to a live part. It is also possible that a fault travels to the area where personnel are at work. In order to prevent such occurrences and to ensure safety of operating personnel, it is necessary to provide a high degree of form of separation.

In Form 4B switchboards:

- Busbars are separated from the functional units
- Functional units are separated from one another
- Separation of terminals for external conductors associated with a functional unit from those of any other functional unit and the busbar
- Terminals for external conductors not in the same compartment as the associated functional unit, but in individual, separate, enclosed protected spaces or compartments

In addition to offering safety, a higher degree of forms of separation also ensures that work can be carried out on a single module without any danger and hence shutdown of healthy feeders is not required. This reduces maintenance downtime.

We provide switchboards up to Form 4B type 6. Form 4B type 7 can be given on request.



Earthing

Proper earthing of all non-current-carrying conducting parts ensures fewer electrical accidents. For this purpose, a distinct vertical earth bar of full length is provided in each front. This ensures positive earthing of all ACB/ modules. A scraping earth contact is provided on each module that makes before all other contacts while inserting the module and breaks last while withdrawing the module. This ensures that the modules remain earthed.

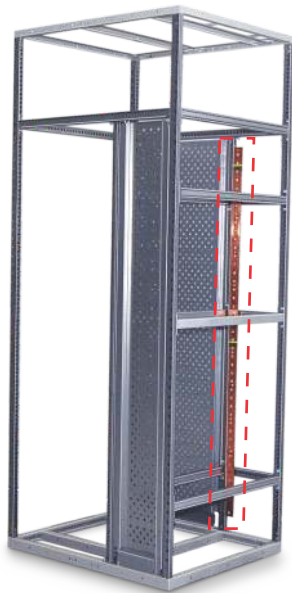

Electrical isolation

The modules have three distinct positions; service, test and isolated. In service position, the power contacts (both incoming and outgoing) and the control contacts are connected. In test position, the power contacts are physically separated whereas the control contacts remain connected. In the isolated position, all the contacts are physically separated. Physical separation ensures foolproof electrical isolation and absolute safety of the operator. All the three positions are achieved with the door closed.



Clearances

The clearances in the busbar zone are higher than those required by the standards. Dielectric withstand of the board is also higher than that required by the latest standard IEC 61439.

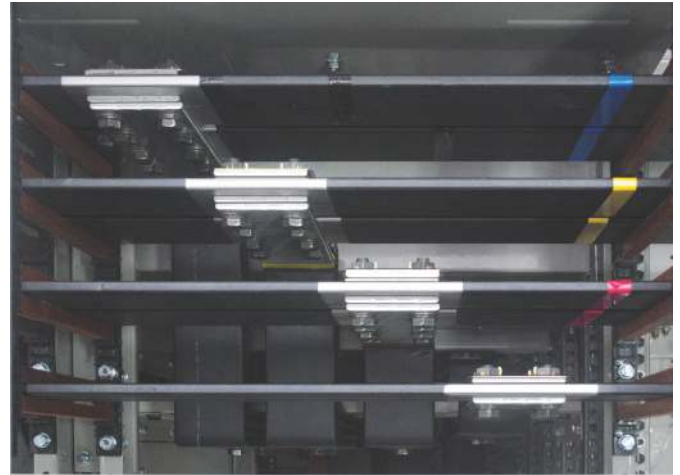

Access

To enhance operator safety, T-Era has special features:

- IP3X separation for vertical busbars even with the module removed
- Safety shutters with padlocking facility
- Finger-touch proof auxiliary contacts
- Padlockable rotary operating handle
- Modules are padlockable in any position
- Padlockable compartment doors

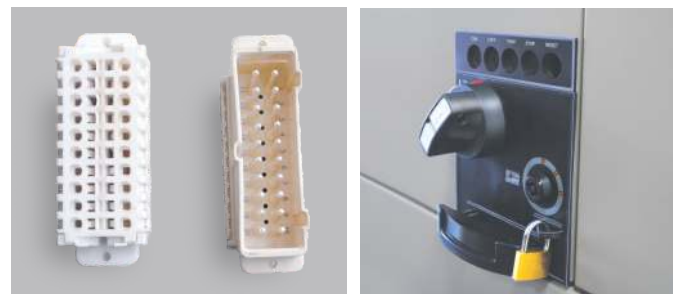



T-Era is available with devices that make it flexible and adaptable to a wide range of uses. Operators can customize the system for optimum advantage.

Cable termination space

Ample space for termination enables faster commissioning. Proper termination of all cables is ensured, making maintenance easier.

Cable termination width is higher than that offered conventionally - up to 460 mm.

Auxiliary busbar and wiring

Auxiliary busbars of screwless type are incorporated – making feeder addition/modification easier. Interpanel control wiring is run in a separate zone which ensures full access to the auxiliary bus during maintenance leading to less troubleshooting time.

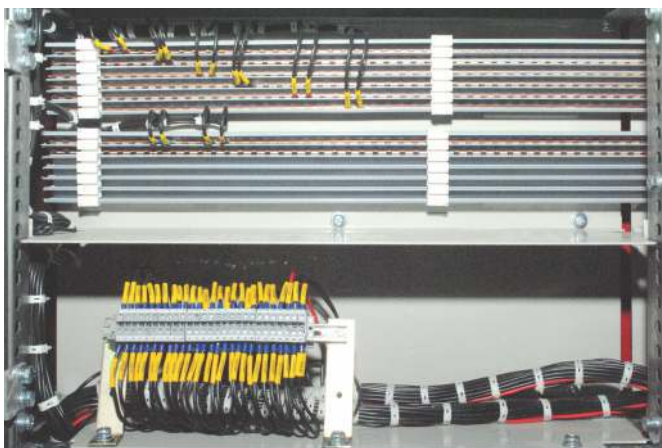

Silver-plated contacts

All power and auxiliary contacts are silver plated. Silver-plated contacts have high abrasion resistance and hence are subject to less wear and tear, leading to a longer life. This leads to lesser downtime of switchboards. They also have lower mV drop.

Indicating lamps

Stack-type lamps specially designed by E&A are used in T-Era. One of the advantages of this type of lamp is ease of wiring. New lamps can be easily added to the existing stack, thus saving time and leading to quicker execution of changes at the manufacturing site. Also, these are LED lamps which consume less energy than conventional lamps and have a longer life.



Hinged doors

All doors are provided with concealed hinges to reduce downtime during maintenance. These doors can only be opened with a special tool as a safety precaution.

Hinged doors mean considerable time saving during routine maintenance.

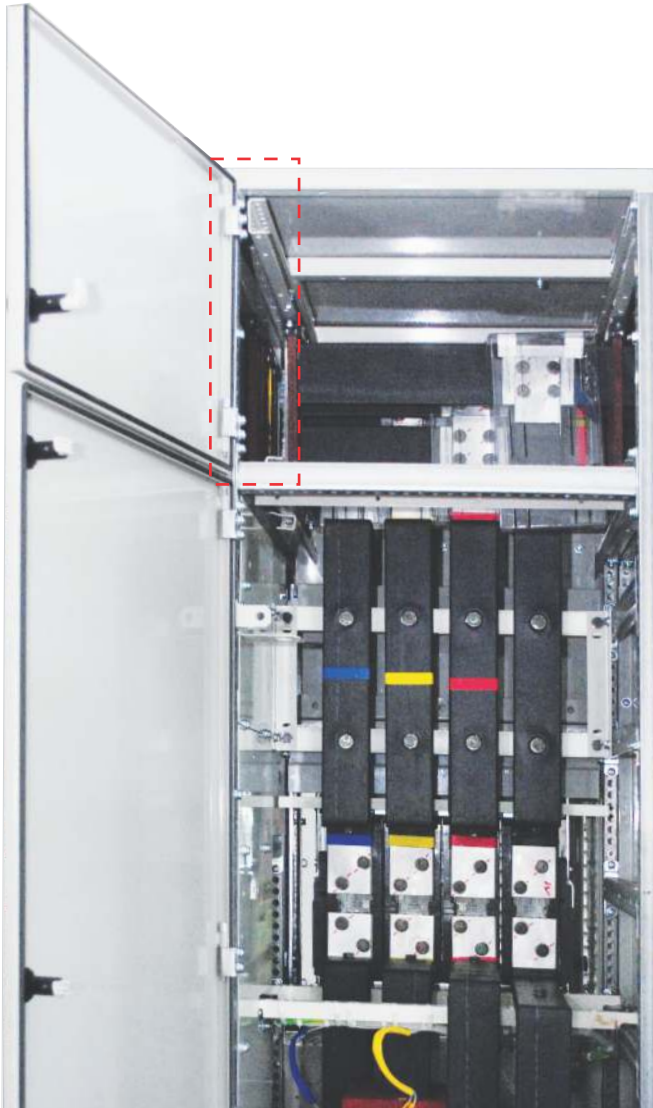

Fully interchangeable modules

The modules are fully interchangeable with an optional rating error preventer. It is also possible to reconfigure the panel by changing the module from quarter to half to full size even at site. Modules can thus be replaced quickly, reducing maintenance downtime.

Positive guidance system

Generally, maintenance is a time-consuming process since insertion and removal of the modules takes time and also depends upon the skill and strength of the operator. To tackle these problems, we have provided a positive guidance system for the module which facilitates faster removal and insertion. This system also ensures the proper engagement of power contacts irrespective of operator skill and strength. Also the modules can be brought from service to test to isolated position by just two quarter turns of the operating handle.

The new mechanism will mean significant time saving while inserting or removing the module.

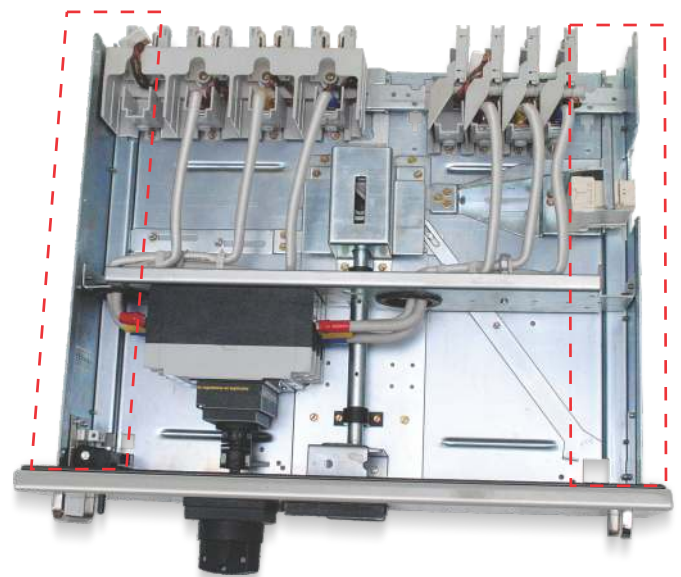

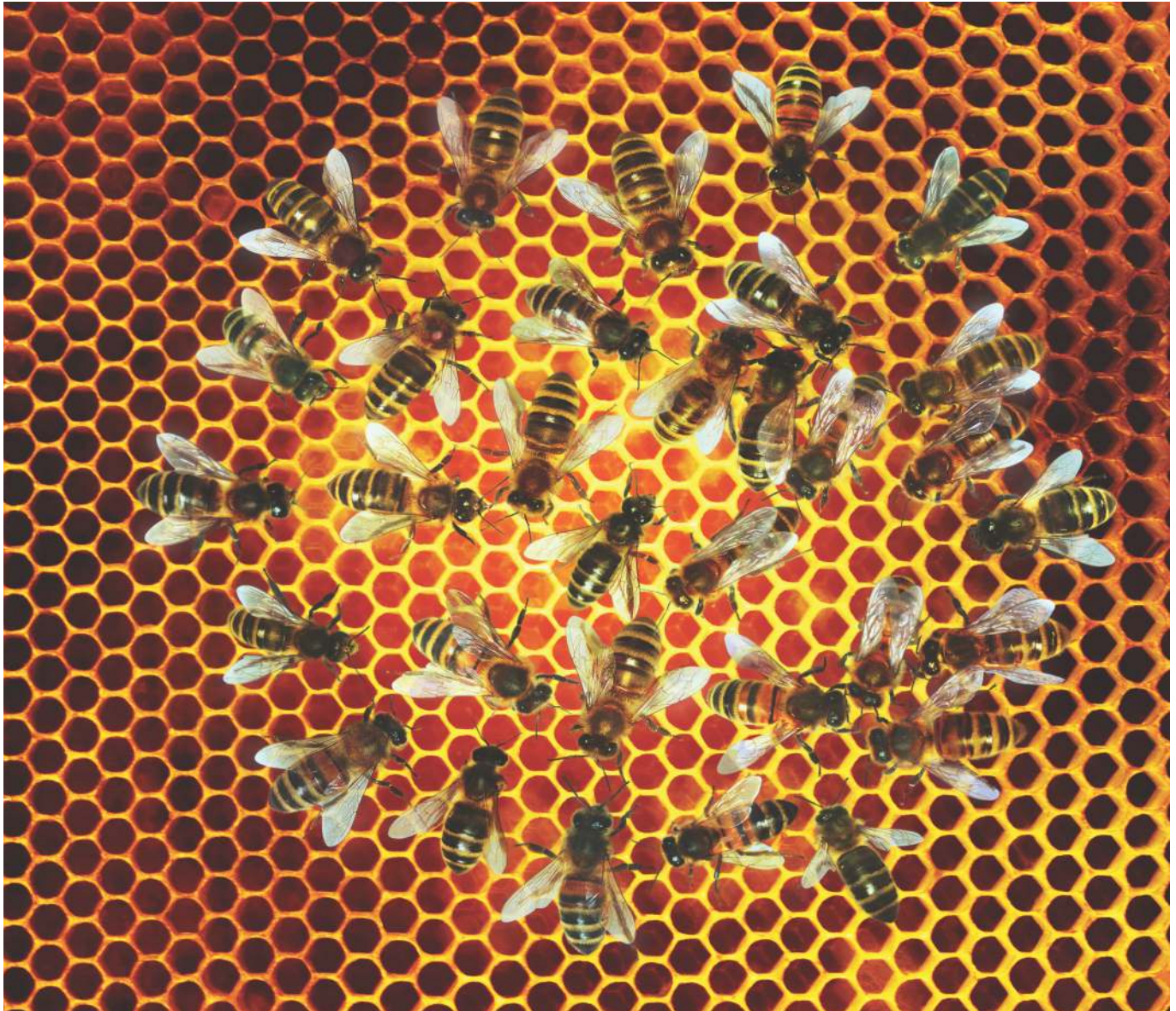

T-Era occupies minimal space and is designed for trouble-free installation. It offers customers multiple permutations for different ratings and different types of feeders, starting with a panel width of 440 mm.

Even at high ratings, a space saving of up to 25% is achieved.

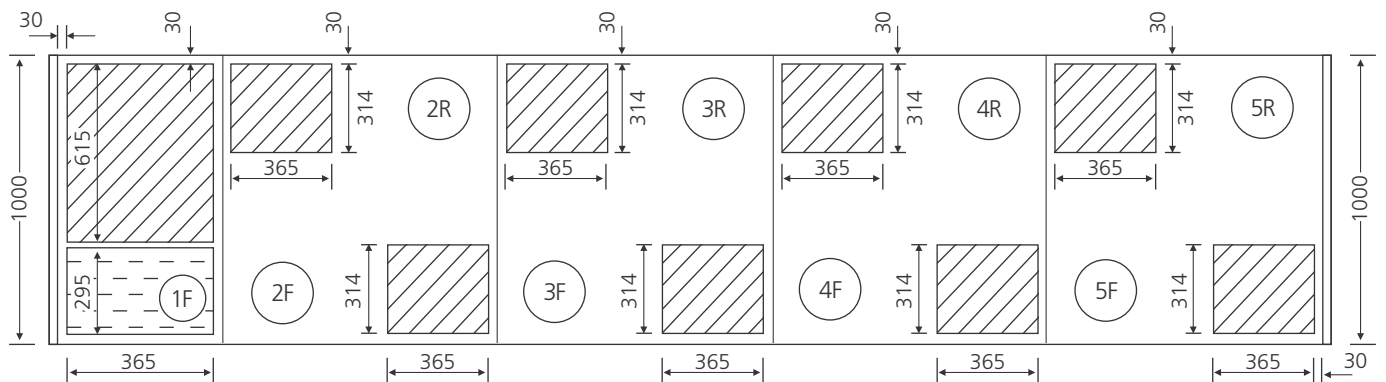

Typical PMCC layout

T Era motor control center offers the choice of rear or side cable alley. MCC panels with side cable alleys require no rear access.

Flexible and compact

Modules in the Motor Control Center are optimized for different ratings. Minimum module height is 160mm.

- Quarter (Q) width modules - 48 quarter width modules rated up to 32A can be fitted in one MCC front
- Half (H) width modules - 24 half width modules rated up to 63A can be fitted in one MCC front
- Full (F) width modules - 12 full width modules rated up to 125A can be fitted in one MCC front

Our unique modular design facilitates the arrangement of several feeders of different sizes in the panel as per your requirements demonstrating flexibility and compactness.

Typical module ratings are :

Compartment size	Maximum current rating
Q	Up to 32A
H	Up to 63A
2Q	Up to 32A
2H	Up to 63A
F	Up to 125A
2F	Up to 160A
3F	Up to 250A
4F	Up to 400A
5F	Up to 500A
6F	Up to 630A

Module size v/s Current Rating

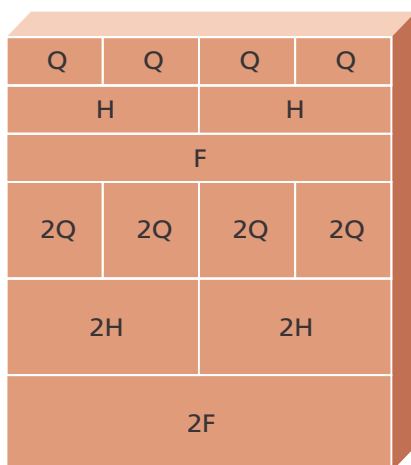

Flexibility of MCC Modules



1Q

2Q

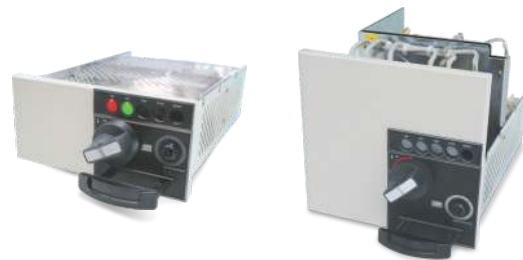

1H

2H



1F



2F



3F



T-Era improves energy efficiency by improving current distribution through a unique arrangement of busbars. This leads to lower electricity consumption and a smaller carbon footprint.

Double-deck arrangement

Skin effect and proximity effect result in uneven distribution of current, reducing the current carrying capacity of the conductors. By using different profiles (orientation of the busbars) it is possible to improve the distribution of the current through the bus bars.

We provide busbars in a double-deck arrangement which leads to lower impedance and hence less heat loss. In this arrangement, the busbars of the same phase are arranged one above the other with the total assembly placed in a horizontal plane. The double-deck arrangement helps to reduce the proximity effect and results in a better distribution of the current through the set of busbars. This arrangement also helps to reduce the electro-dynamic forces between the busbars.



The double-deck arrangement offers energy savings of about 40% over the conventional system.



Conventional System

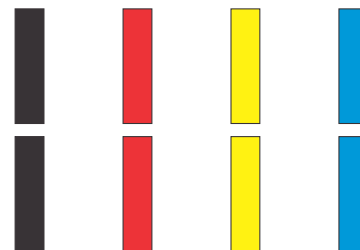

Double-deck arrangement

IMCC

T-Era has been designed for customization. The embedded IEDs (Intelligent Electronic Devices) help in offering integrated solutions and bring multiple benefits:

- Savings by eliminating expensive copper control cabling from & to the T-Era intelligent switchgear
- Flexibility in points of control of the feeders in T-ERA for safe & efficient operation
- Customization of control & monitoring to suit the needs of diverse process and customer needs
- Elimination of multiple discrete devices to achieve control & monitoring, making the switchgear feeder less cluttered & maintenance friendly
- Easy & affordable integration with higher level control & monitoring systems like continuous process plant substations as well as utilities on universally popular communication protocols such as MODBUS, PROFIBUS & IEC 61850 through our own range of relays or relays of any other make
- Unique withdrawable communication module can be offered making a fully withdrawable MCC

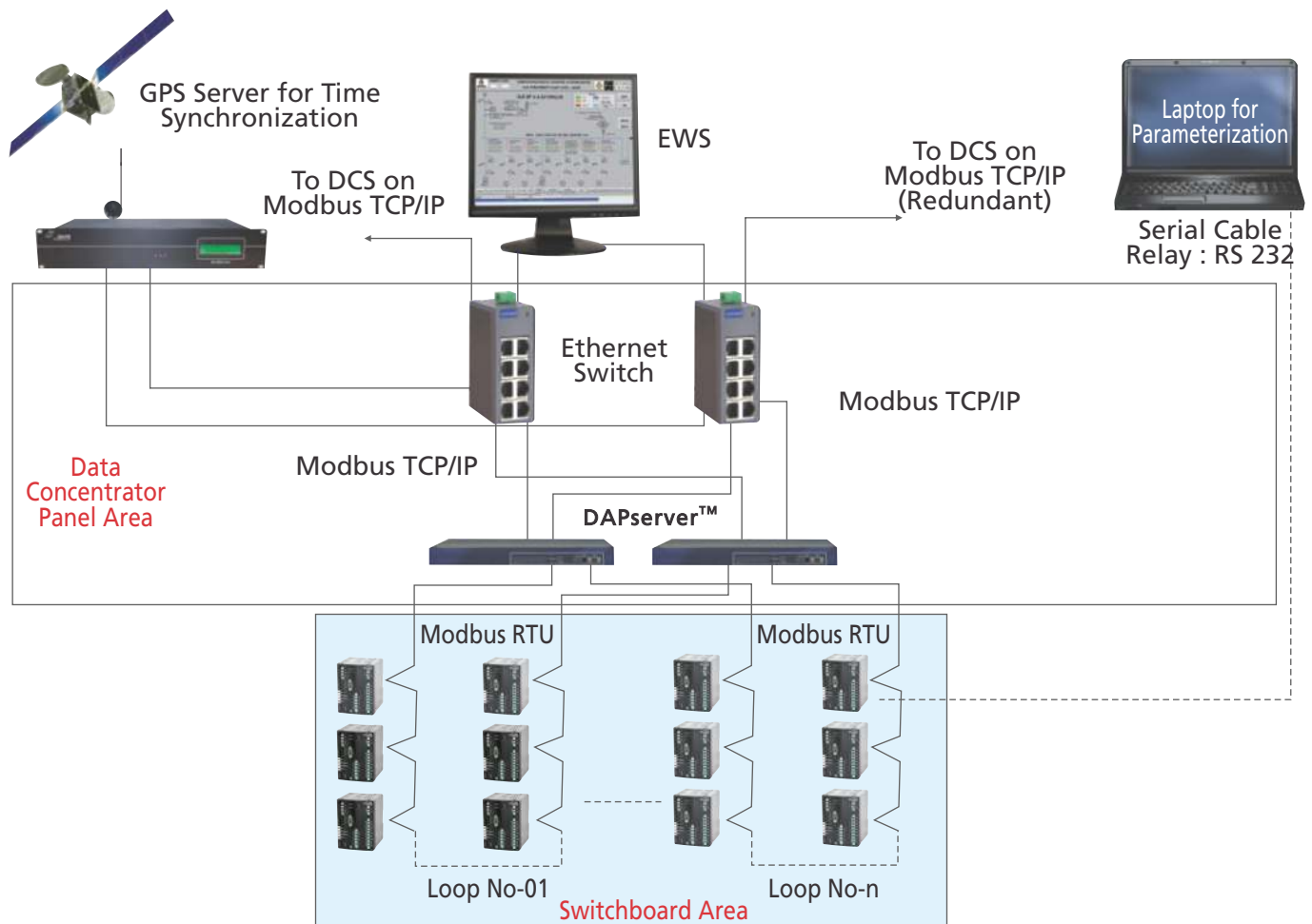



T-Era is manufactured in a world-class facility that adheres to international standards and employs green technologies. It has the advantage of reusable packing, making it environment friendly and compliant with your green agenda.

As far as packing of panels is concerned, it really doesn't get any greener than this.

T-Era gives you reusable packing on request, thus giving you an opportunity to contribute to the environment.

R-Pack - reusable packaging

Packing often turns out to be one of the most environment-unfriendly parts of a product. Generally, in order to pack one panel, the amount of wood used is worth two trees. T-Era's R-Pack design has the advantage of a packing process that is wood-free and is made of reusable plastic material. Further, this packing can be returned to the manufacturer for reuse and in return the customer can be given a free maintenance check up for his switchboard. The packing can be used as many as five times, and then, of course, it can be recycled.

Environment-friendly design

Our facility is ISO 14001 compliant and most of the components used comply to ROHS as well. Continuous improvement in the processes ensures energy savings of 100kWh per year. Numerous green technologies across the manufacturing units are implemented and our factories are LEED certified. All of this leads to a product that promises excellence in all its aspects.

R-Pack complies with international standards and its unique benefits are:

- Strong
- Moisture resistant
- Termite proof
- Saves time
- Cuts costs
- Saves approximately 55000 trees*
- Reduces approximately 5000 tonnes of CO₂ * 2
- Enhances image as a sustainability company

* the calculation is based on our own consumption of the packing material.



R-Pack

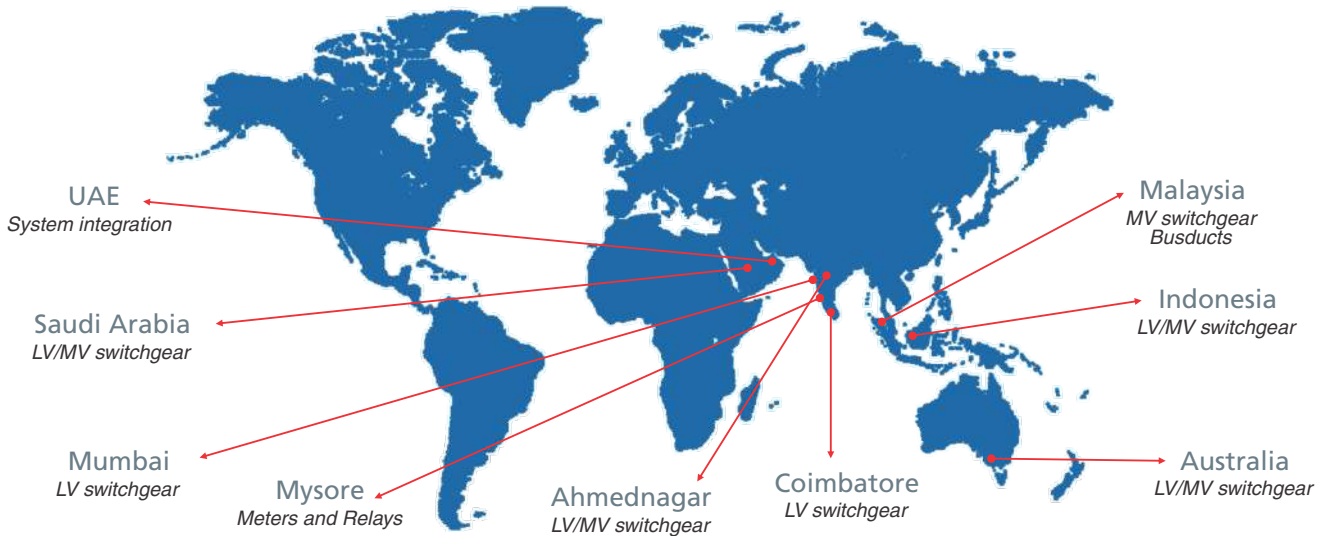

L&T Electrical & Automation has multiple locations globally. Through innovation, we have built a flat-pack design which can be manufactured in a base factory and assembled anywhere in the world. The structure, being modular, can easily accommodate the diverse requirements of different sectors and different geographies.

We ensure our customers get the best quality of switchboard anywhere in the world. Our customers save the time spent in evaluating the suppliers in a new country ensuring that the projects are commissioned as soon as possible at home or abroad.

Our manufacturing practices match the highest standards in the world. All our factories are ISO 9001 certified.

Our modern facilities are very well equipped to manage the worldwide demand for T-Era. They are state-of-the-art factories and have the latest technological machinery and processes in operation, including roll-forming machines, liquid gasketing machines and CNC machines.



Liquid Gasketing

Product quality

With a proven track record of over 60 years, E&A's range of products have worldwide acceptability. We support users in various segments like Metals, Cement, Infrastructure, Oil and Gas, Power - meeting their stringent norms of safety and reliability. At the same time, we are pre-approved by EPC contractors across the world. Superior engineering practices lead to consistency in the product design while accommodating the needs of customers.

The reliability of the panel has increased through compliance to IEC 61439. The additional tests done are:

For insulating parts:

- Verification of thermal stability
- Verification of resistance of insulating materials to normal heat
- Resistance to abnormal heat & fire (glow wire test)

For enclosures :

- Resistance to corrosion test
- Mechanical impact test
- Lifting and marking test



Roll Forming

	PCC (Type TS)	MCC (Type TX)
Rated service voltage	380/415/480/690V	
Rated frequency	50/60Hz	
Rated insulation voltage	1000V	
Rated impulse withstand voltage	12kV	
Busbar system	TP-E or TPN-E	
Rating of horizontal busbars	Up to 6300A	
Fault Level withstand	50/65/80/100kA for 1 sec*	
Degree of protection	IP54/IP42	
Forms of separation	FORM III / IV	
Layouts/Orientations	Single front, back-to-back	
Width	440, 600, 800, 1000	700, 900, 1000, 1060
Depth	600, 1000, 1100, 1260	600, 1100
Height	2200, 2400	2200, 2400
Cable entry	top/bottom (rear)	top/bottom (side/rear)

* 50 kA for 3 sec is also available



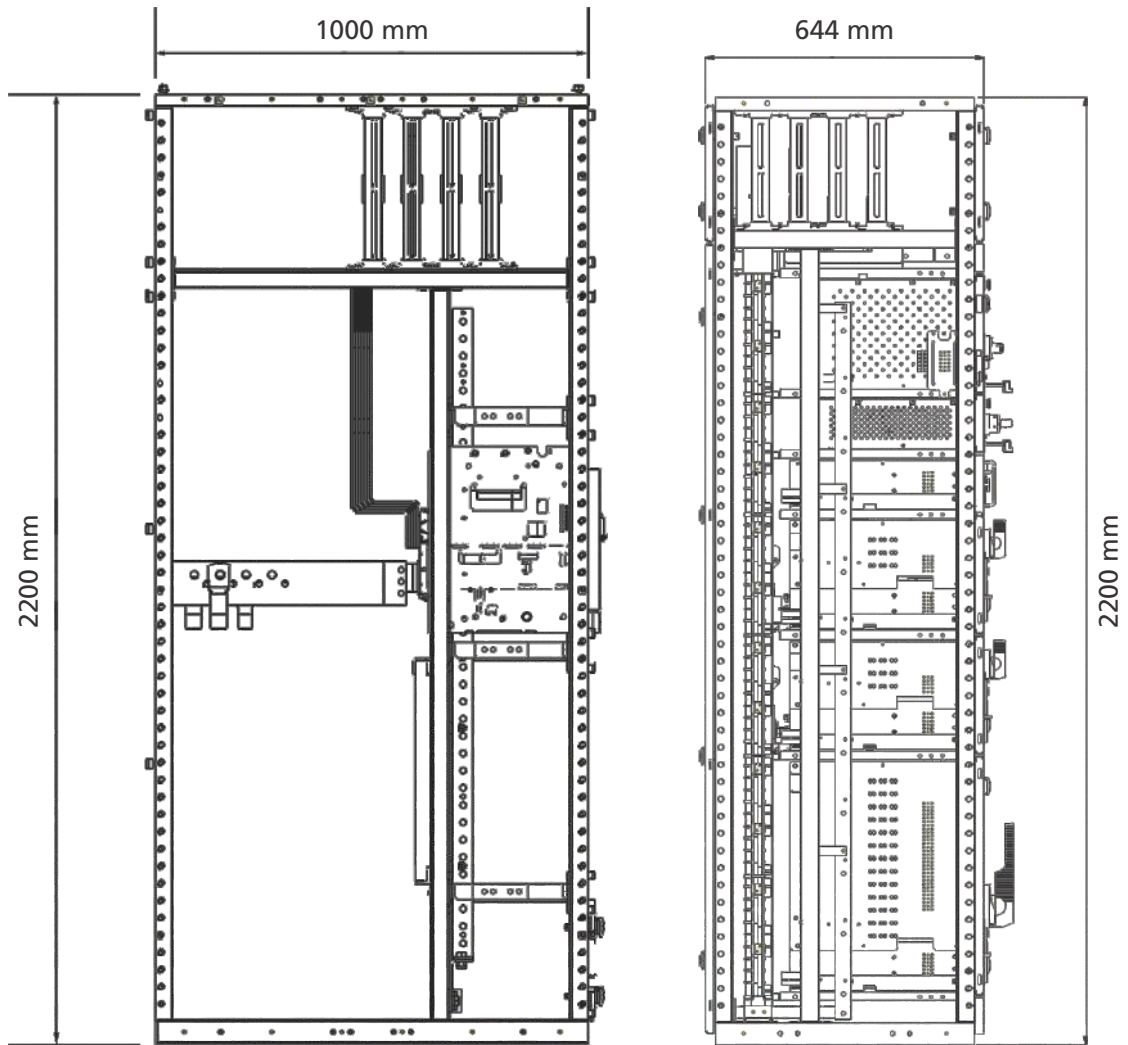

Power Control Centre

Motor Control Centre

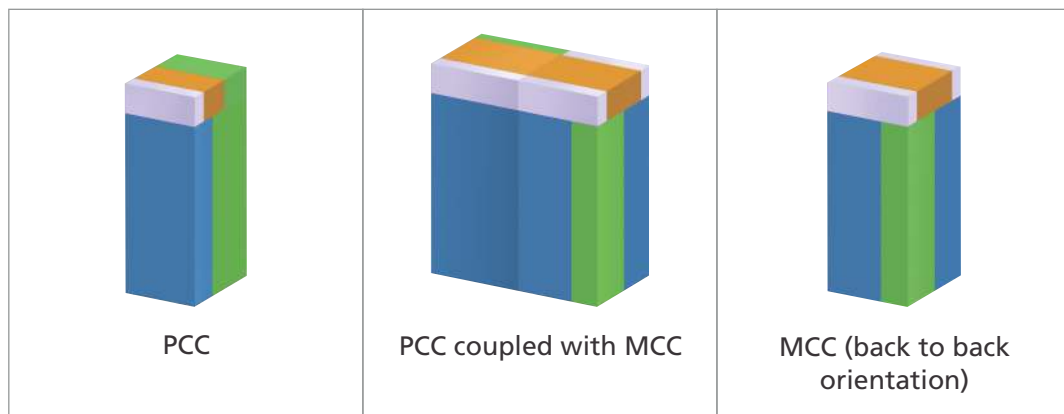

PCC

PCC coupled with MCC

MCC (back to back orientation)

- - Feeders
- - Cable alley
- - Aux. Busbar
- - Busbar

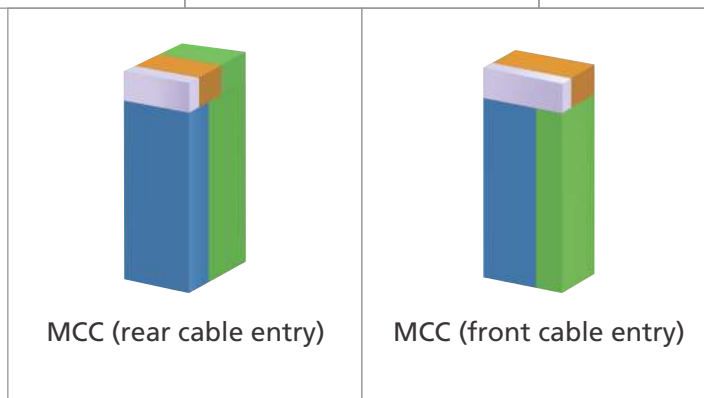

MCC (rear cable entry)

MCC (front cable entry)

Sales Offices - India

Bengaluru

Area office, 38, Cubbon Road
Bengaluru 560001
Tel: 080-25020319
Fax: 080-25596397
Email: ese-chn@Lntebg.com

Chennai

L&T Construction Campus
TC-1 Building, II Floor
Mount-Poonamallee Road
Manapakkam, Chennai 600 089
Tel:+91-44-2270 6801
Fax:+91-44-2270 6930
Email: ese-chn@Lntebg.com

Hyderabad

Post Bag 12, Vasantha Chambers
2nd Floor, 5-10-73, Fateh Maidan Road
Hyderabad 500 004
Tel: +91-40-6672 0210
Fax: +91-40-2324 2356
Email: ese-hyd@Lntebg.com

Kolkata

Post Bag 619
3-B, Shakespeare Sarani
Kolkata 700 071
Tel. : +91-33-4400 2550 / 2558
Fax. : +91-33-22827587 / 1025
Email: ese-ko@Lntebg.com

Mumbai

L&T Gate NO. 5, L&T Business Park TC -II,
Tower B - 7th floor, Saki vihar road,
Mumbai 400 072
Tel:+91-22-6705 3083
Fax:+91-22-6705 1556
Email: ese-intl@Lntebg.com

New Delhi

Post Bag 6223
32, Shivaji Marg
New Delhi 110 015
Tel: +91-11-4141 9620/9942
Fax: +91-11-4141 9625
Email: ese-del@Lntebg.com

Vadodara

Radhadaya Complex, J. P. Road
Vadodara 390 015
Tel: +91-265-66136 37/38
Fax: +91-265-2336 184
Email: ese-vad@Lntebg.com

Sales Offices - International

Australia

TAMCO Electrical Industries Australia Pty
Ltd
31 Kitchen Road, Dandenong 3175
Melbourne, Victoria, Australia
Tel:+613 9706 7288
Fax:+613 9706 9112
Email: sales@tamcoaustralia.com.au
www.tamcoaustralia.com.au

India

L&T Gate NO. 5, L&T Business Park TC -II,
Tower B - 7th floor, Saki vihar road,
Mumbai 400 072
Tel:+91-22-6705 2813
Fax:+91-22-6705 1024
Email: ese-intl@Lntebg.com

Indonesia

PT. TAMCO Indonesia
F-36, Jalan Jababeka Raya
Jababeka Industrial Estate
Cikarang Utara, Bekasi, 17530,Indonesia
Tel.: +62 21 893 5070
Fax: +62 21 893 5071
Email: sales@tamco.co.id
www.tamco.co.id

Kuwait

Kana Controls General Trading &
Contracting Co. W.L.L
P.O Box: 25593 Safat, 13116
Kuwait
Tel: +965-2474 1373
Faxes: +965-2474 1537
Email: ese-kwt@Lntebg.com

Malaysia

TAMCO SWITCHGEAR (MALAYSIA) SDN
BHD
Sub Lot 24, Lot 16505, Jalan Keluli 1
PO Box 2100, Bukit Raja Industrial Area,
Section 7
40802 ShahAlam, Selangor, Malaysia
Tel: +603 3361 8200
Fax: +603 3341 6200
Email: tamco@tamco.com.my
www.tamco.com.my

Oman

P.O.Box 598, Ruwi, Postal Code-112
Sultanate of Oman
Tel:+968 98034317
Mob:+968 98034317
EMail: ese-oman@Lntebg.com

Qatar

2 & 3rd Floor, Building No. 209
Zone 42, Street 230
Najma Intersection, Opp: Doha Cinema
C-Ring Road,P.O Box No- 24399
Doha, Qatar
Tel: +974-44-239 000
Fax: +974-44-551 286
Email: ese-qatar@Lntebg.com

UAE

2203, 22nd Floor
Green Emirates Tower - A
Electra Street, P.O. Box 52514
Abu Dhabi, UAE
Tel. : +971-2-676 5988
Fax. : +971-2-676 6399
Email: ese-uae@Lntebg.com



L&T Electrical & Automation, Electrical Systems & Equipment - Head Office

7C, TC II, Tower B, Level 7, L&T Gate No. 5, Saki Vihar Road, Powai, Mumbai 400 072.
Tel: +91-22-6705 1748 Fax: +91-22-6705 1556
Email: ese-cmt@Lntebg.com Website: www.Lntebg.com

The information contained herein is correct at time of printing, but as the products and its manufacturing processes are being developed continuously, this information is subject to change without notice and the company cannot be held liable for any alleged misinterpretation howsoever arising.